



## Main

Range of product	Easypact CVS100...250
Product or component type	Circuit breaker
Device short name	CVS100F
Device application	Distribution
Poles description	3P
Protected poles description	3d
Earth leakage protection (Vigi add on)	Without
[In] rated current	100 A at 40 °C
Breaking capacity code	F
Network type	AC
[Icu] Breaking capacity	36 kA Icu at 440 V AC 50/60 Hz conforming to IEC 60947-2 36 kA Icu at 380/415 V AC 50/60 Hz conforming to IEC 60947-2 70 kA Icu at 220/240 V AC 50/60 Hz conforming to IEC 60947-2
Utilisation category	Category A
Trip unit name	TM-D
Trip unit technology	Thermal-magnetic
Trip unit rating	100 A at 40 °C
Protection type	Short-circuit protection (magnetic) Overload protection (thermal)

## Complementary

Network frequency	50/60 Hz
Control type	Toggle
Mounting mode	Fixed
Mounting support	Backplate
Upside connection	Front

Downside connection	Front
Connections - terminals	Screw connection
[Uimp] rated impulse withstand voltage	8 kV conforming to EN/IEC 60947-2
Thermal protection adjustment range	70...100 A
[Ics] rated service breaking capacity	18 kA at 440 V AC 50/60 Hz conforming to IEC 60947-2 36 kA at 380/415 V AC 50/60 Hz conforming to IEC 60947-2 70 kA at 220/240 V AC 50/60 Hz conforming to IEC 60947-2
Mechanical durability	30000 cycles
Electrical durability	12000 cycles 415 V In conforming to IEC 60947-2
Connection pitch	35 mm
Contact position indicator	Yes
Long time pick-up adjustment type Ir	Adjustable
Long time pick-up adjustment range	0.7...1 x In
Long time delay adjustment type	Fixed
Instantaneous pick-up adjustment type li	Fixed
Instantaneous pick-up adjustment range	800 A
Height	161 mm
Width	105 mm
Depth	86 mm
Product weight	1.8 kg

## Environment

Electrical shock protection class	Class II
Standards	IEC 60947-2 EN 60947-2
Product certifications	IEC GOST
IP degree of protection	IP40
Pollution degree	3 conforming to IEC 60664-1
Ambient air temperature for operation	-25...70 °C
Ambient air temperature for storage	-50...85 °C

## Packing Units

Unit Type of Package 1	PCE
Number of Units in Package 1	1
Package 1 Weight	1.671 kg
Package 1 Height	11 cm
Package 1 width	14 cm
Package 1 Length	19 cm
Unit Type of Package 2	S03
Number of Units in Package 2	6
Package 2 Weight	10.446 kg
Package 2 Height	30 cm
Package 2 width	30 cm
Package 2 Length	40 cm

## Offer Sustainability

Sustainable offer status	Green Premium product
REACH Regulation	<a href="#">REACH Declaration</a>
EU RoHS Directive	Compliant <a href="#">EU RoHS Declaration</a>
Mercury free	Yes

RoHS exemption information	<a href="#">Yes</a>
China RoHS Regulation	<a href="#">China RoHS declaration</a> Product out of China RoHS scope. Substance declaration for your information
Environmental Disclosure	<a href="#">Product Environmental Profile</a>
Circularity Profile	<a href="#">End of Life Information</a>
WEEE	The product must be disposed on European Union markets following specific waste collection and never end up in rubbish bins

### Contractual warranty

Warranty	18 months
----------	-----------

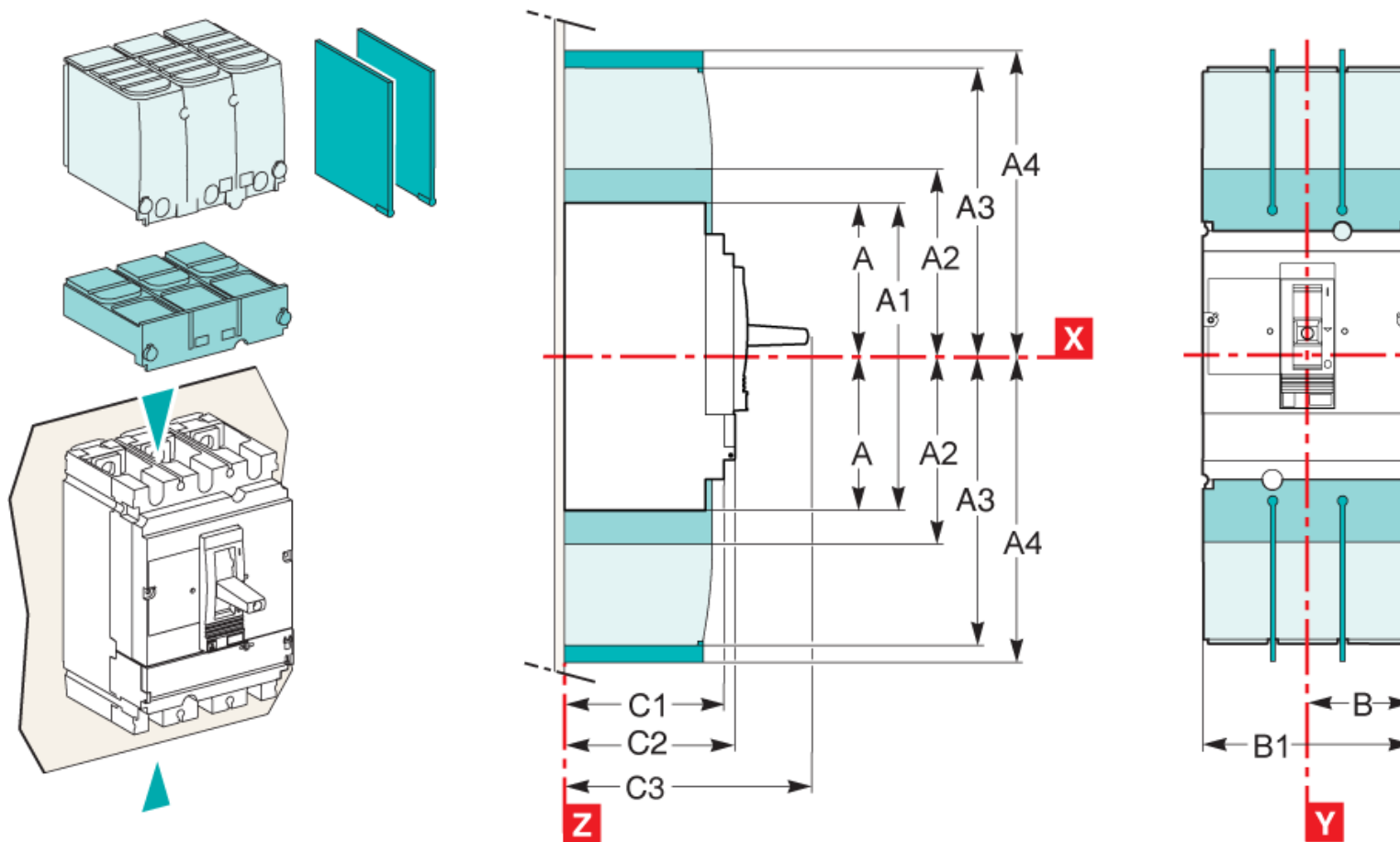

Type	A	A1	A2	A3	A4	A5	A6	A7	A8	A9	B	B1	B2	C1	C2	C3	E1
CVS100I60/250	80.5	161	94	145	178.5	155.5	236	169	220	253.5	52.5	105	140	81	86	111 <sup>Ø</sup>	62.5
CVS400E30	127.5	255	142.5	200	237	227.5	355	242.5	300	337	70	140	185	95.5	110	168	100
Type	E2	E3	E4	E5	E6	E7	E8	F1	F2	F3	G1	G2	G3	G4	G5	ØT	U
CVS100I60/250	125	70	140	137.5	200	145	215	35	17.5	70	96	75	13.5	23	17.5	24	y 32
CVS400E30	200	113.5	227	200	300	213.5	327	45	22.5	90	-	-	-	-	32	y 35	

Ø1 C3=126mm for EasyPact CVS250B.F.

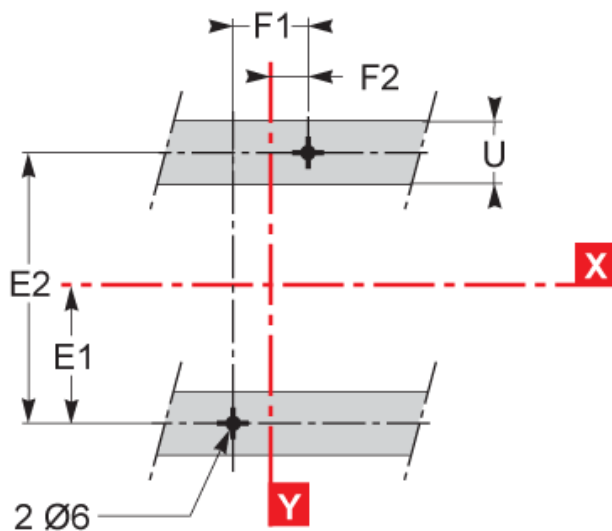
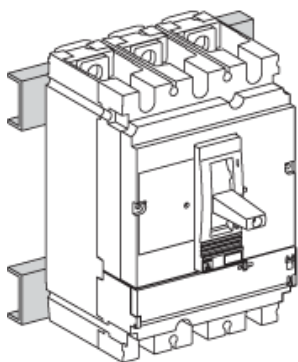
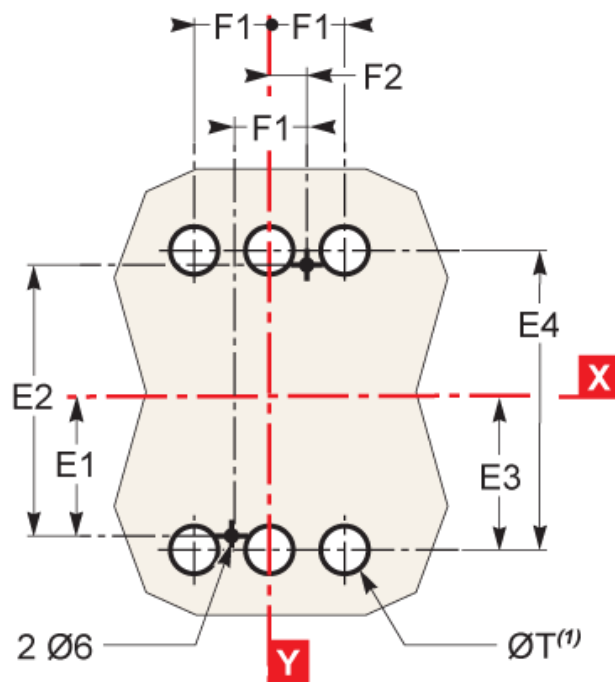
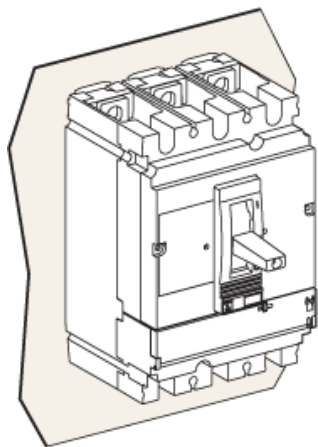

Type	A	A1	A2	A3	A4	A5	A6	A7	A8	A9	B	B1	B2	C1	C2	C3	E1
CVS100/160/250	80.5	101	84	145	178.5	155.5	236	109	220	253.5	52.5	105	140	81	86	111 <sup>(2)</sup>	62.5
CVS400/630	127.5	255	142.5	200	237	227.5	365	242.5	300	337	70	140	185	95.5	110	168	100
Type	E2	E3	E4	E5	E6	E7	E8	F1	F2	F3	G1	G2	G3	G4	G5	ØT	U
CVS100/160/250	125	70	140	137.5	200	145	215	35	17.5	70	95	75	13.5	23	17.5	24	y 32
CVS400/630	200	113.5	227	200	300	213.5	327	45	22.5	90	-	-	-	-	32	y 35	

(2) C3=126mm for EasyPact CVS250B.F.

